

4

3

2

1

## IMPORTANT NOTES

# TECHNICAL DRAWING CAN NOT BE REPRODUCED OR SHARED WITHOUT PERMISSION.  
 # ALL PERMISSION OF TECHNICAL DRAWING BELONG TO KARANFİL CIVATA.  
 # ASSURANCE WITH THE IATF 16949 VE ISO 14001 CERTIFICATE  
 # ALL DIMENSIONS ACCORDING TO MM.  
 # PLEASE DO NOT MEASURE THROUGH PAPER.  
 # PLEASE FOLLOW THE REVISIONS ON THE TECHNICAL DRAWING.

REVISION NO	NAME	TITLE	SIGNATURE	REVISION DATE	REVISION INFORMATION
00	TOLGA KARANFİL	PRODUCTION MANAGER		23.01.2023	-

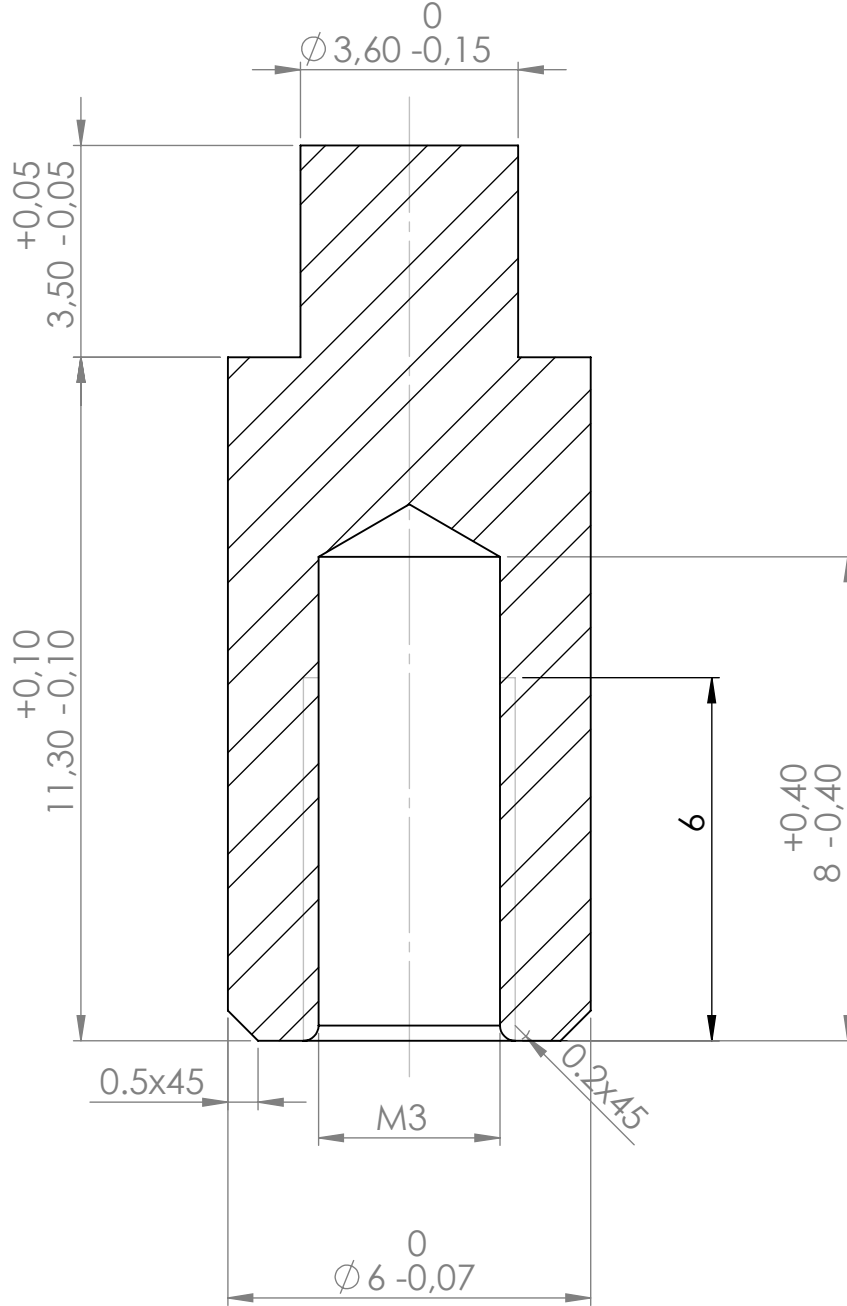

KESIT A-A  
 ÖLÇEK 8 : 1

NAME	TITLE	SIGNATURE	DATE	PRODUCT NAME : M3 KILAVUZ PİMİ	
DRAW.				DRAWN NO : TD.NDW.230123001	
CONTROL	TOLGA KARANFİL	PRODUCTION MANAGER	23.01.2023	MATERIAL : SAE 1006-C	HARDNESS : - HRc
APPLIER				COATING : Cr+3	WEIGHT : 2,30 gr
				HEAT TREATMENT : NONE	REVISION NO : REV.00
				CUSTOMER : -	
				SCALE : -	PAGE1 / 1

4

3

2

1