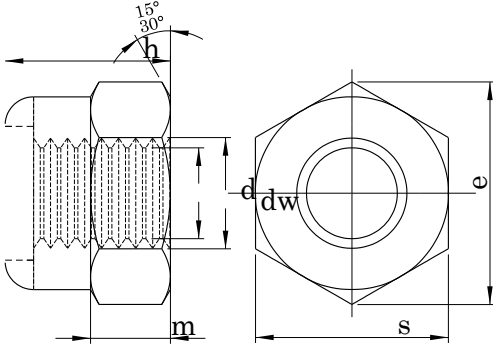

DIN 982 ISO 7040
FİBERLİ ALTİKÖŞE YÜKSEK SOMUN
PREVALING TORQUE TYPE HEXAGON NUTS WITH NONMETALLIC INSERT
SECHSKANTMUTTER MIT NICHTMETALLISCHEM KLEMMTEIL, HOCH

Technical Informations / Teknik Bilgiler

		(d)	M6	M8	M10	M12
Thread size / Anma çapı (d)		(d x p)		M8 X 1,00	M10 X 1,00	M12 X 1,50
Pitch / Diş adımı		p			M10 X 1,25	M12 X 1,25
Diagonal / Köşegen	d	max. a	6,75	8,75	10,00	13,00
	d _w	min.	min. 6,00	8,00	10,80	12,00
	e	min.	8,90	11,60	15,60	17,40
Height / Yükseklik	h	nom.=max.	11,05	14,38	18,90	21,10
	m	min.	8,00	9,50	11,50	14,00
Head width / Anahtar ağızı s	m'	min.	7,70	9,14	11,14	13,64
		min.	4,90	6,44	8,04	10,37
		min.	3,92	5,15	6,43	8,30
Weight / Ağırlık		nom.=max.	10,00	13,00	17,00	19,00
		min.	9,78	12,73	16,73	18,67
	ar/b		3,10	6,00	11,70	16,60

Values are given in millimeters. / Değerler milimetre olarak verilmiştir.