

DIN 6921 ISO EN 1665

ALTIKÖŞE BAŞLI FLANŞLI CIVATA CL:8.8 - 10.9 - 12.9

**HEXAGON HEAD FLANGE BOLTS
SECHSKANTSCHRAUBE MIT
FLANSCH**

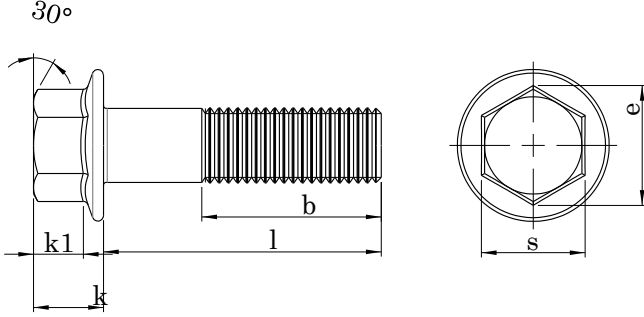

Technical Informations / Teknik Bilgiler

Thread size / Anma çapı (d)		M5	M6	M8	M10	M12	M14	M16	
Pitch / Diş adımı	P	0,80	1,00	1,25	1,50	1,75	2,00	2,00	
Flange dia / Flanş çapı	dc	11,80	14,20	18,00	22,30	26,60	30,50	35,00	
Flange height / Flanş yüksekliği	c	1,00	1,10	1,20	1,50	1,80	2,10	2,40	
Head height / Kafa yüksekliği	k	5,40	6,60	8,10	9,20	11,50	12,80	14,40	
	k1	2,00	2,50	3,20	3,60	4,60	5,10	5,80	
Head width / Anahtar ağızı	s	min.	7,78	9,78	12,73	14,73	15,73	17,73	20,67
		max.	8,00	10,00	13,00	15,00	16,00	18,00	21,00
Diagonal / Köşegen	e	8,71	10,95	14,26	16,50	17,62	19,86	23,15	
Thread length / Diş uzunluğu	b ¹	16,00	18,00	22,00	36,00	30,00	34,00	38,00	
	b ²	-	-	28,00	32,00	36,00	40,00	44,00	

Thread size / Anma çapı (d)		M5	M6	M8	M10	M12	M14	M16
Length / Boy	min.	Weight / Ağırlık gr/p						
	max.							
10	9,71	10,29	3,22					
12	11,65	12,35	3,46	6,94	13,76	24,04		
16	15,65	16,35	3,94	7,62	15,01	26,01		
20	19,58	20,42	4,42	8,30	16,25	27,97	44,35	
25	24,58	25,42	5,25	9,16	17,80	30,42	47,90	66,13
30	29,58	30,42	6,00	10,50	19,36	32,88	51,46	71,01
35	34,50	35,50	6,74	11,58	21,77	35,33	55,02	75,89
40	39,50	40,50	7,48	12,65	23,68	39,18	58,57	80,76
45	44,50	45,50	8,23	13,73	25,60	42,20	64,20	85,64
50	49,50	50,50	8,97	14,80	27,52	45,21	68,54	93,45
55	54,40	55,60	9,71	15,88	29,44	48,23	72,87	99,37
60	59,40	60,60	10,46	16,96	31,36	51,24	77,21	105,30
65	64,40	65,60	11,20	18,03	33,27	54,25	81,55	111,20

DIN 6921 ISO EN 1665

ALTIKÖŞE BAŞLI FLANŞLI CIVATA CL:8.8 - 10.9 - 12.9

HEXAGON HEAD FLANGE BOLTS

SECHSKANTSCHRAUBE MIT FLANSCH

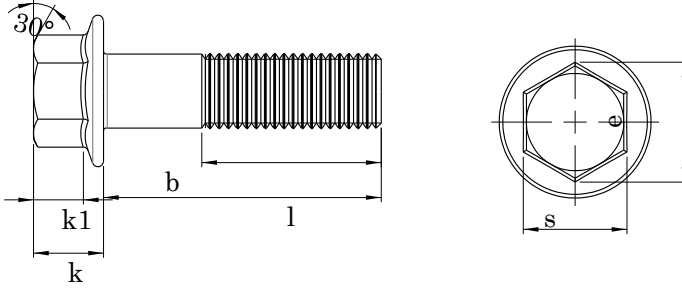

Technical Informations / Teknik Bilgiler

Thread size / Anma çapı (d)		M5	M6	M8	M10	M12	M14	M16
Pitch / Diş adımı	P	0,80	1,00	1,25	1,50	1,75	2,00	2,00
Flange dia / Flanş çapı	dc	11,80	14,20	18,00	22,30	26,60	30,50	35,00
Flange heigth / Flanş yüksekliği	c	1,00	1,10	1,20	1,50	1,80	2,10	2,40
Head height / Kafa yüksekliği	k	5,40	6,60	8,10	9,20	11,50	12,80	14,40
	k1	2,00	2,50	3,20	3,60	4,60	5,10	5,80
Head width / Anahtar ağızı	s min.	7,78	9,78	12,73	14,73	15,73	17,73	20,67
	s max.	8,00	10,00	13,00	15,00	16,00	18,00	21,00
Diagonal / Köşegen	e	8,71	10,95	14,26	16,50	17,62	19,86	23,15
Thread length / Dis uzunluğu	b ¹	16,00	18,00	22,00	36,00	30,00	34,00	38,00
	b ²	-	-	28,00	32,00	36,00	40,00	44,00

Thread size / Anma çapı (d)		M5	M6	M8	M10	M12	M14	M16	
Length / Boy	min.								
	max.								
		Weight / Ağırlık gr/p							
70	69,40 70,60	11,94	19,11	35,19	57,27	85,89	117,10	150,00	
80	79,40 80,60	13,43	21,26	39,03	63,29	94,56	129,00	166,00	
90	89,30 90,70		23,41	42,87	69,32	103,20	140,80	181,10	
100	99,30 100,70		25,57	46,70	75,35	111,90	152,70	197,00	
110	109,30 110,70				81,38	120,60	164,50	212,00	
120	119,30 120,70				87,40	129,30	176,40	228,00	
130	129,20 130,80				92,76	137,00	187,00	242,00	
140	139,20 140,80					145,70	198,80	257,00	
150	149,20 150,80						210,70	273,00	
160	159,20 160,80								
180	179,20 180,80								
200	199,00 201,00								