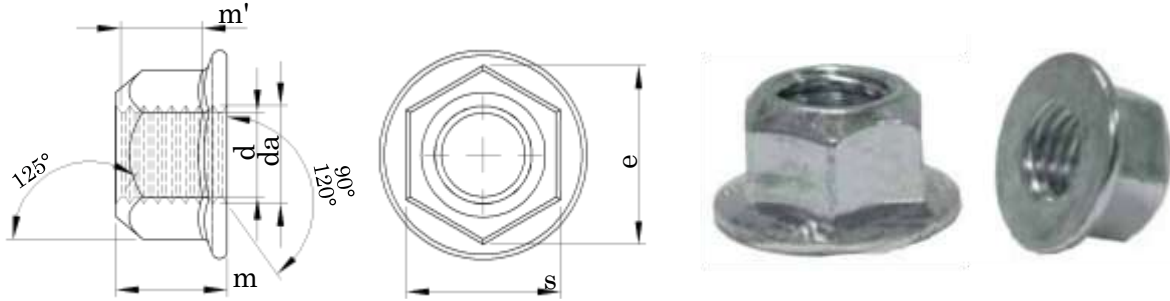

DIN 6927 ISO 7044
**ALTI KÖŞE SIKMALI FLANŞLI SOMUN
 PREVAILING TORQUE TYPE HEXAGON NUTS WITH FLANGE
 SICHERUNGSMUTTER MIT FLANSCH**

Technical Informations / Teknik Bilgiler

Thread size / Anma çapı (d)		M6	M 8	M10	M12	M14
Pitch / Diş adımı	p1		8×1.00	10×1.00	12×1.25	14×1.50
	p2			10×1.25	12×1.50	
	p3	1,00	1,25	1,50	1,75	2,00
Head width / Anahtar ağızı	min.	10,00	13,00	15,00	18,00	21,00
	s	9,78	12,73	14,73	17,73	20,67
Diagonal / Köşegen	e	11,05	14,38	16,64	20,03	23,36
	m	5,70	7,60	9,60	11,60	13,30
Height / Yükseklik	m'	3,10	4,50	5,50	6,70	7,80
	c	1,00	1,20	1,50	1,80	2,10
dw	min.	12,20	15,80	19,60	23,80	27,60
	da	6,00	8,00	10,00	12,00	14,00
dc	min.	6,75	8,75	10,80	13,00	15,10
	max.	14,20	17,90	21,80	26,00	29,90
h	min.	7,30	9,40	11,40	13,80	15,90
	r	0,36	0,48	0,60	0,72	0,88
Weight / Ağırlık	gr/p	3,50	7,85	12,54	25,30	34,00

Values are given in millimeters. / Değerler milimetre olarak verilmiştir.