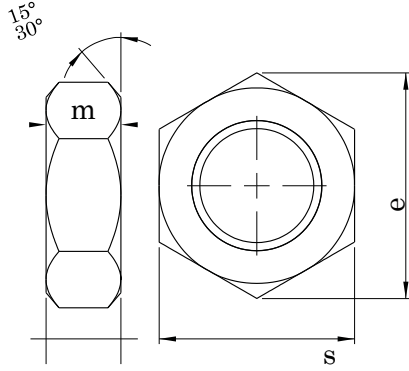

DIN 936
**ALTI KÖŞE KONTRA SOMUN HEXAGON
 THIN NUT SECHSKANTMUTTERN
 (NIEDRIG)**

Technical Informations / Teknik Bilgiler

Thread size / Anma çapı (d)		M6	M8	M10	M12	M14	M16	M18	M20
Pitch / Diş adımı	P1			1,00	1,25			1,50	1,50
	P2		1,00	1,25	1,50	1,50	1,50	2,00	2,00
	P3	1,00	1,25	1,50	1,75	2,00	2,00	2,50	2,50
Head width / Anahtar ağızı	s								
	min.		12,73	16,73	18,67	21,67	23,67	26,16	29,16
	max.	10,00	13,00	17,00	19,00	22,00	24,00	27,00	30,00
Diagonal / Köşegen	e								
	max.		14,38	18,90	21,10	24,49	26,75	29,56	32,95
Height / Yükseklik	m								
	max.	3,00	5,00	6,00	7,00	8,00	8,00	9,00	9,00
	min.		4,70	5,70	6,64	7,42	7,42	8,42	8,10
Weight / Ağırlık	gr/p	1,50	4,00	8,60	12,10	18,20	20,10	29,60	36,30

Values are given in millimeters. / Değerler milimetre olarak verilmiştir.