

4

3

2

1

**IMPORTANT NOTES**

# TECHNICAL DRAWING CAN NOT BE REPRODUCED OR SHARED WITHOUT PERMISSION.  
 # ALL PERMISSION OF TECHNICAL DRAWING BELONG TO KARANFİL CIVATA.  
 # ASSURANCE WITH THE IATF 16949 VE ISO 14001 CERTIFICATE  
 # ALL DIMENSIONS ACCORDING TO MM.  
 # PLEASE DO NOT MEASURE THROUGH PAPER.  
 # PLEASE FOLLOW THE REVISIONS ON THE TECHNICAL DRAWING.

REVISION NO	NAME	TITLE	SIGNATURE	REVISION DATE	REVISION INFORMATION
00	TOLGA KARANFİL	PRODUCTION MANAGER		01.03.2023	-

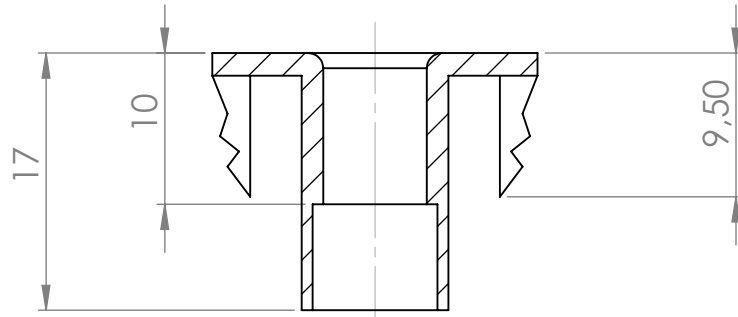
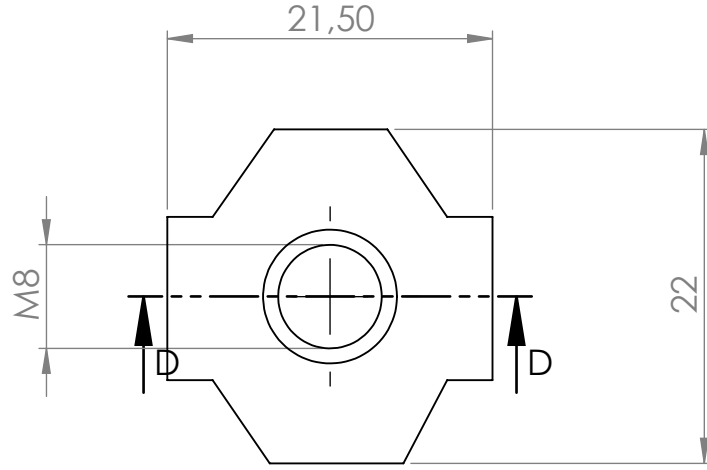

KESIT D-D

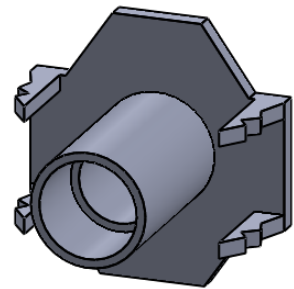

	NAME	TITLE	SIGNATURE	DATE	PRODUCT NAME : M8*17 AĞAÇ SOMUN
DRAW.					DRAWN NO : TD.NDW.230301013
CONTROL	TOLGA KARANFİL	PRODUCTION MANAGER		01.03.2023	MATERIAL : QS136-3 HARDNESS : - HRc
APPLIER					COATING : NONE WEIGHT : - gr
			MANUFACTURING METHOD		HEAT TREATMENT : NONE REVISION NO : REV.00
			COLD FORMING WITH THE 1786S		CUSTOMER : -
			SCALE : -		PAGE1 / 1

4

3

2

1